

Republic offers a complete line of regenerative blowers for high vacuum or compressed air applications in both horizontal and vertical mounted positions. TEFC motors are rated for 50/60 Hz operation and are CE certified. The impeller is directly connected to the motor shaft, providing powerful air force without undue friction. The bearings are outside the compression chamber, ensuring maximum operational reliability under high differential pressure. This low-maintenance, oil-free design provides continuous, dependable service to our customers.

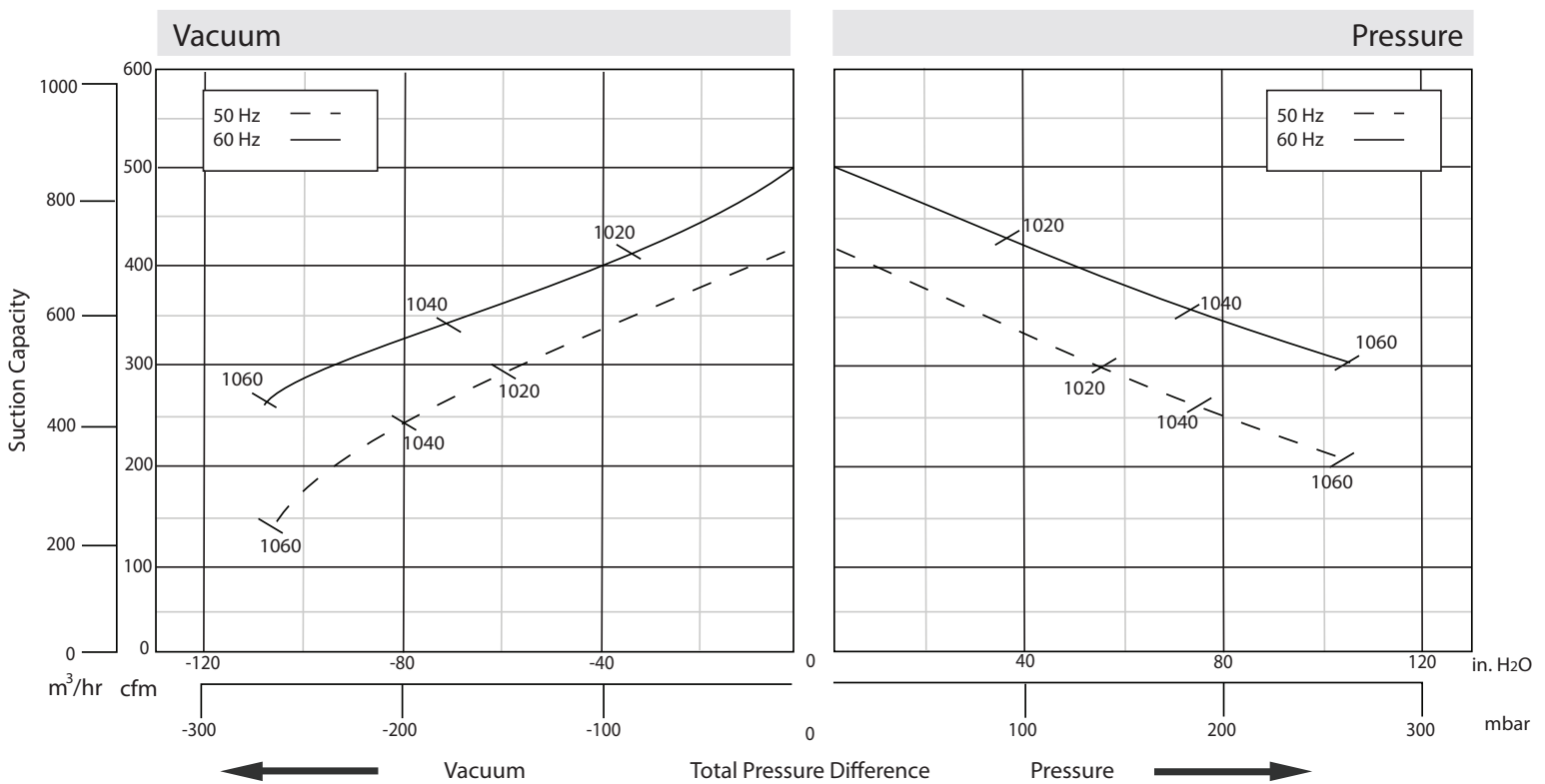

PERFORMANCE



Model	Phase	Frequency (Hz)	Air flow (CFM/m ³ /hr)	Rated Vacuum (in. H ₂ O/mbar)	Rated Pressure (in. H ₂ O/mbar)	Motor (HP/kW)	Voltage (V)	Current (A)	Sound Level (dB)	Weight (lb/kg)
HRB 1020	3	50	412/700	60/149	56/139	5.4/4.0	200-240 Δ/345-415 Y	15.6 Δ/9.0 Y	74	126/57
		60	494/840	36/90	36/90	6.2/4.6	220-275 Δ/380-480 Y	15.6 Δ/9.0 Y		
HRB 1040	3	50	412/700	80/199	76/189	7.4/5.4	200-240 Δ/345-415 Y	23.0 Δ/13.3 Y	74	146/66
		60	494/840	72/179	72/179	8.4/6.2	220-275 Δ/380-480 Y	23.0 Δ/13.3 Y		
HRB 1060	3	50	412/700	108/269	104/259	10.1/7.4	200-240 Δ/345-415 Y	29.0 Δ/16.7 Y	74	153/69
		60	494/840	108/269	104/259	11.5/8.5	220-275 Δ/380-480 Y	30.0 Δ/17.3 Y		

The performance curves are based on air at a temperature of 59 °F and an atmospheric pressure of 29.91 inch Hg with a tolerance of +/-10%. The total pressure differences are valid for inlet and ambient temperatures up to 77 °F. Suction capacity relates to inlet conditions. Pressure capacity relates to atmospheric conditions. For other conditions please contact Republic. Three phase motor tolerances are +/-10% for fixed voltage motors and +/-5% for voltage range motors. Single phase machines are designed with a +/-5% tolerance. The frequency tolerance is +/-2% maximum.

APPROXIMATE DIMENSIONS

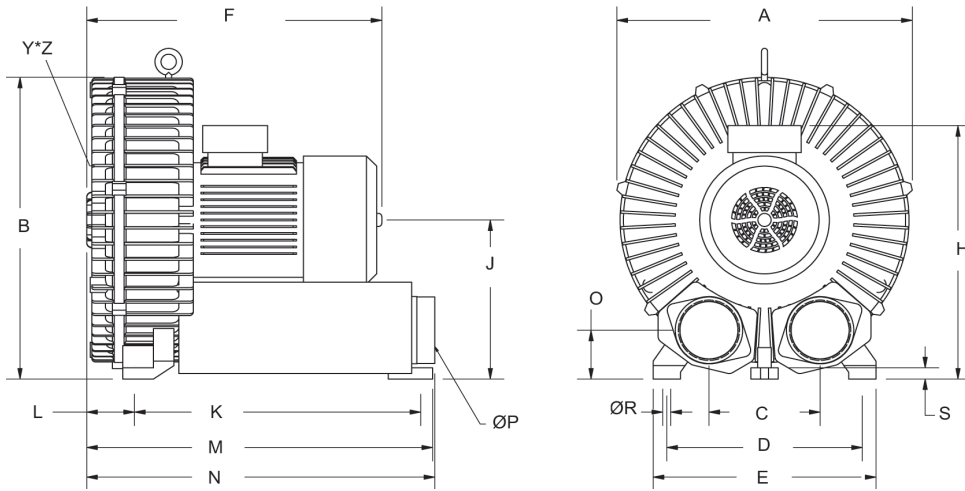

Model	Unit	A	B	C	D	E	F	H	J	K	M	N	O	ØP	ØR	S	Y*Z
HRB 1020	in	11.76	18.15	5.98	14.02	15.51	18.35	15.28	9.45	12.17	17.68	17.68	2.56	2.5	15	0.24	M12
	mm	451	461	152	356	394	466	388	240	309	449	449	65				
HRB 1040	in	11.76	18.15	5.98	14.02	15.51	19.37	16.02	9.45	12.17	17.68	17.68	2.56	2.5	15	0.24	M12
	mm	451	461	152	356	394	492	407	240	309	449	449	65				
HRB 1060	in	11.76	18.15	5.98	14.02	15.51	19.37	16.02	9.45	12.17	17.68	17.68	2.56	2.5	15	0.24	M12
	mm	451	461	152	356	394	492	407	240	309	449	449	65				

Available Options

All Republic Regenerative Blowers are available in pre-assembled kits for either pressure or vacuum applications. These kits include an inlet filter, gauge and relief valve, and are factory tested prior to shipment. Optional items for these kits include check valve, and tube adaptor; washdown motors, explosion proof motors, or other specialty motors; noise enclosures; and control panels such as VFD's, PLC's, or starter panels.

VACUUM KIT

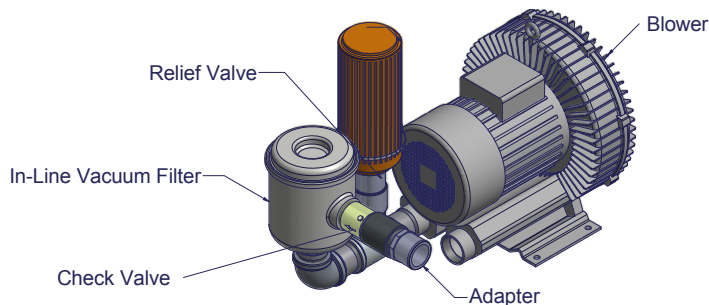

PRESSURE KIT

