

Republic offers a complete line of centrifugal blowers for vacuum or compressed air applications. Centrifugal blowers provide dry, clean, oil-free air and require low energy consumption. Unlike compressed air systems, this series is safe to run at low pressure, and allows for increased production speeds or levels.

The RB500 is Republic's smallest centrifugal blower, and is robust and hard-working. The blower comes with ceramic hybrid bearings, rotatable outlet discharge, easy to remove stainless steel bearing housing assembly, and zinc plated steel motor pulley.



## PERFORMANCE

Vacuum Pressure

### 60Hz

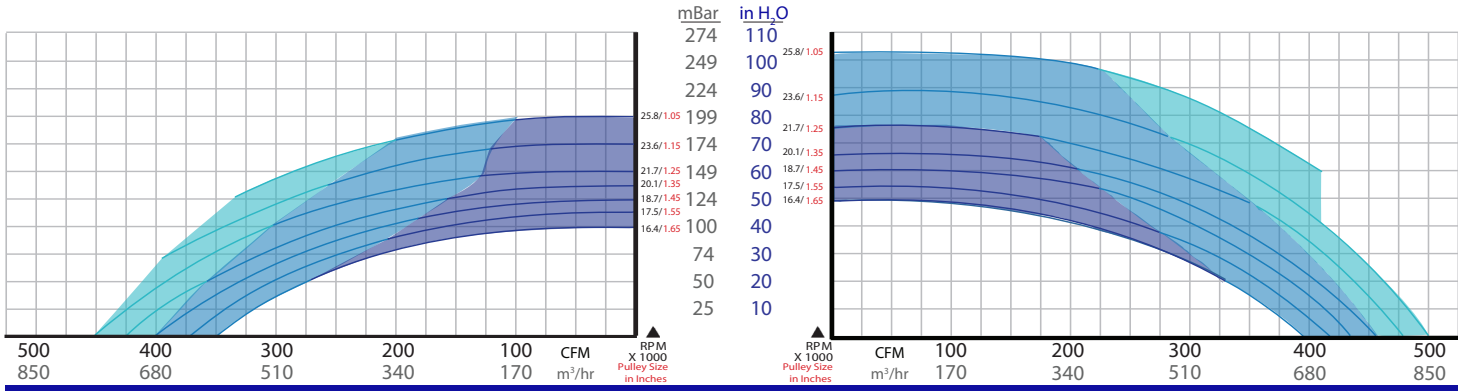

### 50Hz

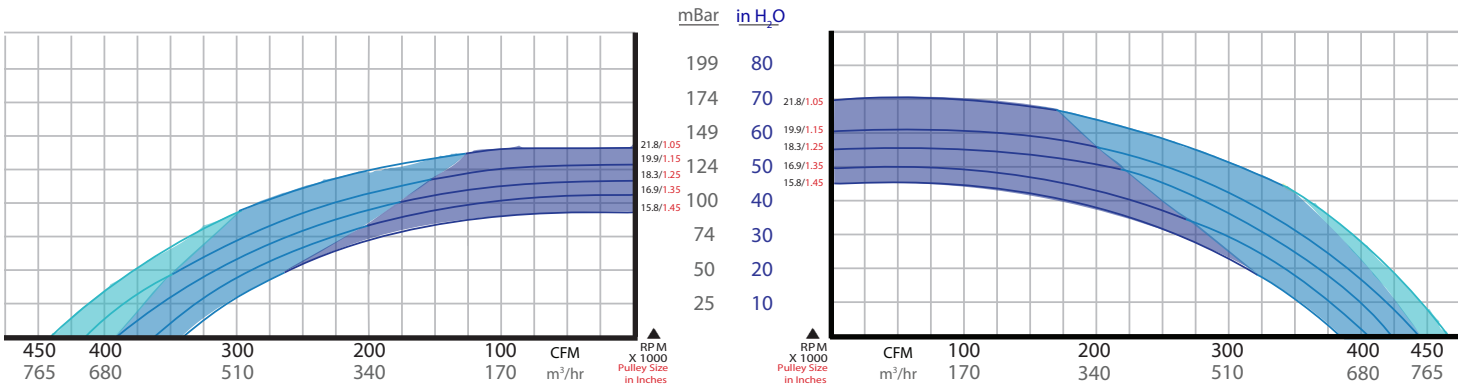

Standard cubic feet per minute, air at 14.7 PSIA, 68°F, 36% R.H.  
 1" H<sub>2</sub>O = 0.074" Hg = 0.036 PSIG = 0.57 oz = 25.4 mm H<sub>2</sub>O

■ 3HP    ■ 5HP    ■ 7.5HP

Model	Frequency (Hz)	HP	Max Flow (CFM/m <sup>3</sup> /hr)	Max Vacuum (in. H <sub>2</sub> O/mbar)	Max Pressure (in. H <sub>2</sub> O/mbar)	Sound Level (db) with Enclosure/without Enclosure	Weight (lb/kg)	Retro Kit Weight (lb/kg)
RB500	50	3 (182TC)	320/544	56/140	70/174	75/82	120/54	50/23
	60		330/561	80/200	76/189			
	50	5 (184TC)	440/758	55/137	67/167	75/82	131/59	
	60		455/773	79/197	102/254			
	50	7.5 (213TC)	465/790	38/95	45/112	75/82	180/81	
	60		500/850	71/177	97/242			

## APPROXIMATE DIMENSIONS

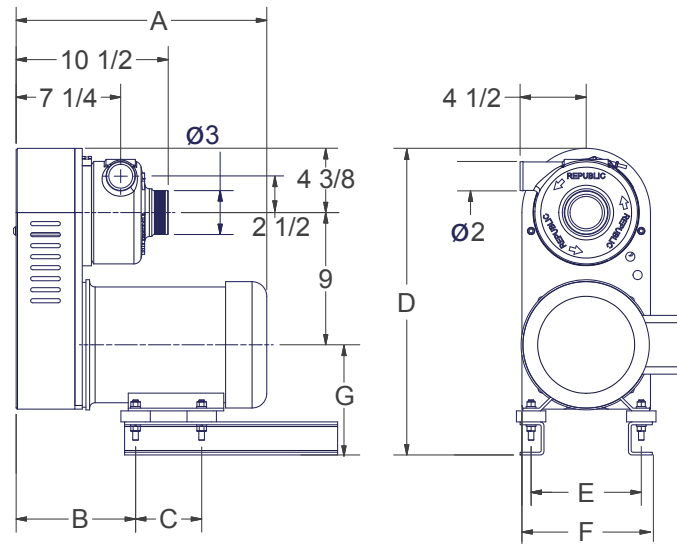

HP	Unit	A	B	C	D	E	F	G
<b>3</b> <b>(182TC)</b>	in	17.31	7.50	4.50	20.94	7.50	9.00	7.50
	mm	440	191	114	532	191	229	191
<b>5</b> <b>(184TC)</b>	in	18.31	7.50	5.50	20.94	7.50	9.00	7.50
	mm	465	191	140	532	191	229	191
<b>7.5</b> <b>(213TC)</b>	in	20.13	8.38	5.50	21.69	8.50	10.00	8.50
	mm	511	213	140	551	216	254	216

### Available Options

Republic Centrifugal Blowers are made to order, and can be customized to fit almost any application. Many common options and accessories are listed below. For additional options, please contact Republic or your local distributor.

#### Advantages

- 3-7.5 Horsepower – up to 25,000 rpm
- 10 Groove self-tensioning belt for long life
- Lightweight & small footprint
- Ceramic hybrid bearings
- Multi-lip seals on both ends of the shaft
- 2" Blower outlet discharge is rotatable
- Precision balanced shaft/impeller assemblies
- Stainless steel blower pulley, zinc plated steel motor pulley, and aluminum blower housing
- 6061 T6 aluminum impeller
- Bearing housing is steel construction for extra rigidity
- Operational with all types of motors– washdown, explosion proof, high efficiency and hydraulic
- Easy to remove bearing/impeller housing for quick repair
- 100% Operational performance and vibration tested
- One year warranty

#### Options

- Hard anodized bearing housing assembly
- Inlet and outlet flanges
- Water-cooled blower

#### Accessories

- Enclosures for noise control
- Exhaust silencer
- Starter panel
- Variable frequency drive