

CE



**R E P U B L I C**  
*Vacuum Pumps®*



# **Single Stage Rotary Vane Vacuum Pump**

## **Installation and Operation Manual**

**RX-10**

**RX-21**

**RX-25**

**Republic Vacuum Pumps®**

**[www.republicsales.com](http://www.republicsales.com)**

Revised 10.14

© 2014 Republic Sales & Manufacturing



# Single Stage Rotary Vane Vacuum Pump

## Installation and Operation Manual

For models RX-10, RX-21 and RX-25

### Republic Vacuum Pumps®

5131 Cash Road

Dallas, TX 75247

(800) 847-0380

[www.republicsales.com](http://www.republicsales.com)

[info@republicsales.com](mailto:info@republicsales.com)

### Warning

Service procedures should only be performed by trained service personnel.

### Important

Read the following safety instructions carefully. Disconnect vacuum pump from electrical source before beginning service.

# Table of Contents

**Safety Instructions.....04**

**Connection and Operation.....05**

**Introduction and Process Overview.....06**

**Dimensions.....07**

**Connection Diagram.....08**

**Installation.....08**

**Maintenance.....09**

**Model Specifications..... 10**

**Replacement Vanes, Filters & Oil..... 10**

**Parts Breakdown..... 11**

**Exploded Parts Diagram..... 11**

        RX-10 Parts List..... 12

        RX-21 Parts List..... 13

        RX-25 Parts List..... 14

**Common Problems & Solutions..... 15**

## Safety Instructions



1. Always make sure power is switched off and unplugged prior to maintenance.



2. Check vacuum pump for any damage that may have occurred during transportation.



3. Do not dispose of solid material directly into suction inlet or use filter before inlet. Doing so may cause damage to the vacuum pump.



4. Do not dispose of acid, alkali or inflammable gas. Doing so may cause an explosion or damage.



5. Do not dispose of high temperature liquid or air.



6. Do not touch the running vacuum pump; surface temperature may rise during continuous operation and can reach temperatures over 176°F. Keep clear of the connector.



7. Do not operate beyond over-loading mark on rating label.



8. Storage conditions:
  - Dry
  - Dust-Free
  - Low vibration (<2.8mm/s)
  - Ambient temperature <104°F

## Connection and Operation



- Make sure the voltage and frequency of power supply fits the requested electrical condition marked on pump rating plate or label, otherwise injury or motor damage may occur due to incorrect voltage. Standard power supply for the vacuum pump motor is 230v/380v/460v/3ph/50hz/60hz.



- Wire according to the wiring instruction inside the cover of terminal box, and connect ground lines to prevent an electrical leakage accident.



- Install overload protection according to the voltage marked on rating plate or label and choose the appropriate overload device.



- Avoid turning pump switch on and off more than 10 times per hour, otherwise motor may overheat.

## Operation

### Before start

1. Shut off air intake port.
2. Check the direction of rotation. If incorrect exchange any two phases.
3. Switch on.
4. Open the air intake port.
5. Switch off.
6. Shut off the air intake port.
7. Turn off the power switch.

### Preparing for a Long-Term Stop

If the vacuum pump will not be used for over two months, close down all open ports and store in a dry location, away from dust. Before restarting after long term stop, complete the following steps:

1. Manually rotate vanes to ensure they are not stuck before starting the motor.
2. Change all the lubrication and run for 30 minutes.
3. Follow the before start steps listed above.

## Vacuum Pump Introduction

RX series vacuum pumps are single-vane rotary oil-sealing pumps, which are suitable for 18 inHgV to 29.96 inHgV vacuum field removal of dry air. They can be used alone or with booster pumps. These are highly efficient and reliable vacuum pumps.

Pumps run on the vane principle. The rotor (11), installed off-center, revolves inside the pump (10), and centrifugal force moves the vane (12). The vane (12) divides the space between the pump housing (10) and the rotor (11) into several working spaces. When the working space is connected to an air inlet, it vacuums air. The continuous running of the rotor compresses the air, which is then drawn into the oil separator (1). The pressure difference pumps lubricant oil into the pump housing. Lubricant oil and air are separated and discharged into the oil separator (10) and exhaust filters (4). When the oil reaches the bottom of the oil separator (10), it enters the oil reservoir again via the float valves (6), while the non-oil air is expelled via the exhaust port (5).

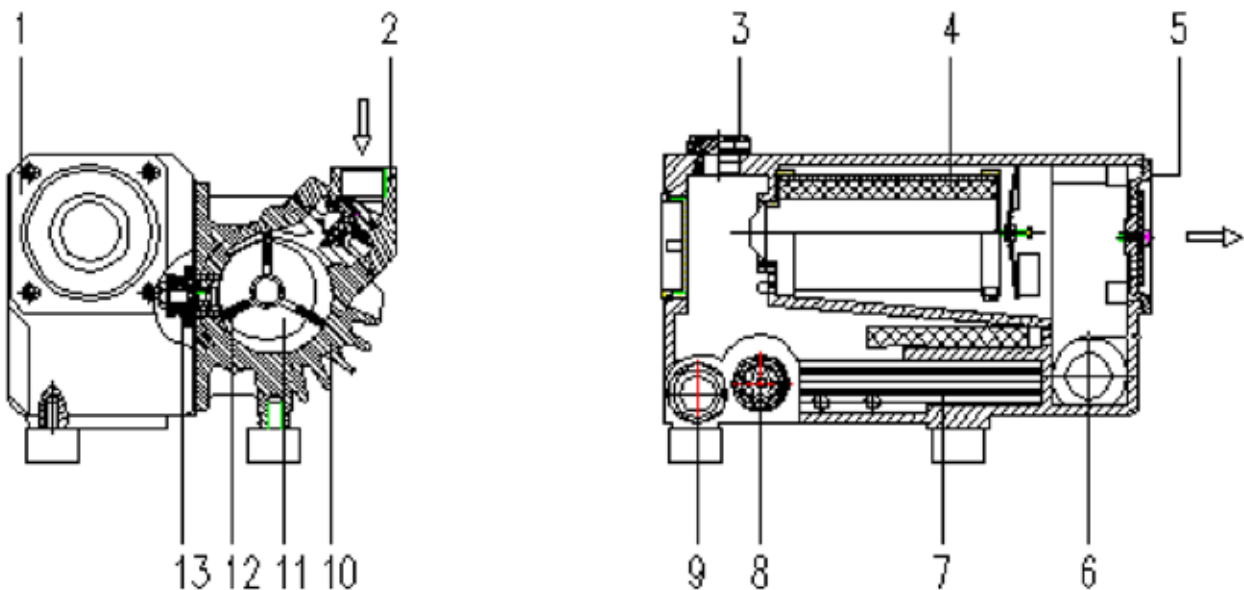

## Air Process

After dust is removed by the inlet air filter, the air goes into the pump body through the inlet valve and mixes with the oil. The mixed air will be compressed through the exhaust valve, and then filtered by the exhaust filter. The oil-free air will be exhausted to the atmosphere. The gas ballast should be open if there is moisture in the air.

The inlet air filter is a dry paper filter. It should be removed and cleaned every 1000 working hours. To clean the filter, blow low pressure air from the inside to the outside. The inlet valve (2) cannot be used as a vacuum system check valve or the vane (12) may rotate in the opposite direction after the machine is switched off.

The pump is equipped with a gas ballast valve, which can be partially or completely closed. A little air enters the pump body through the gas ballast valve and is compressed with the processed air. This way, the moisture inside the process will not cause the oil to coagulate.

Before operation, the air inlet should be closed for 30 minutes until the internal temperature reaches 167°F, which will allow any moisture to evaporate. After use, run the motor another 30 minutes so that any condensation in the pump oil evaporates.

## Lubrication Process

Due to the pressure difference between the oil separator (1) and the pump body, the lubrication is separated in to three parts: the first part is cooled in the oil coil and is then injected into the vacuum body to cool the air. The second part goes into both sides of the pump body to cool the bearing housing. The spare lubrication moves into the vacuum body to cool the air. The oil injected into the vacuum body with the inlet air enters the oil separator (1) through the exhaust valve (13) as oil mist. After the oil mist hits the oil separator (3), some oil returns to the bottom of the oil separator (10) while some oil will be separated by the exhaust filter (4). After being separated by the filter, the oil gathers in the float valve (6) and returns to the vacuum body through the float valve (6). From here the cycle starts over.

The air-cooling vacuum pump is very sensitive to the environmental temperature, so the ambient air temperature and condition should be considered when choosing placement of the vacuum pump. If the environment is not optimal, the cooling fan will be covered with dust, which adversely affects the performance. Dust should be removed with low pressure compressed air. If it cannot be removed completely, a solvent should be used and the heat dissipation surface of the oil coil should be kept dry.

The exhaust filter (4) is made from multilayer fiberglass. The oil mist will be removed almost completely by the exhaust valve. The exhaust filter (4) can work for about 3000 hours under normal working conditions, but the lube quality and the pollution of the nearby environment will affect the life of the filter. If the environment is too polluted, consider adding a pre filter. We recommend using our vacuum pump oil (SHV series), as other brands or reconditioned oil will reduce the performance of the vacuum pump.

## Approximate Dimensions (in inches)

Model	A	B	C	D	E	F	G	H	I	J	K	L	M
RX-10	9	8	8	1	5	9	7	8	18	8	1	5	0.75
RX-21	9	8	8	1	5	9	7	8	19	8	1	5	0.75
RX-25	9	8	8	1	5	9	7	8	19	8	1	5	0.75

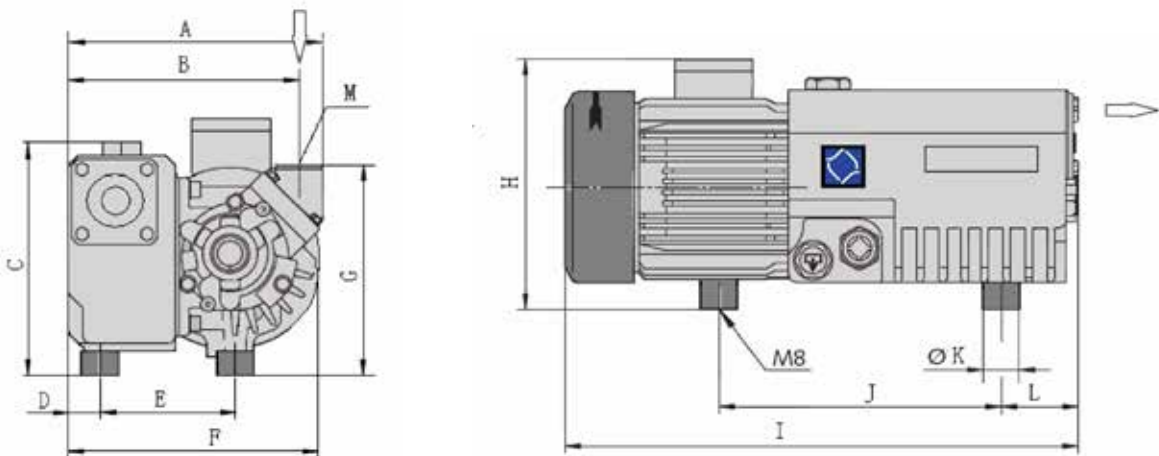

## Connection Diagrams

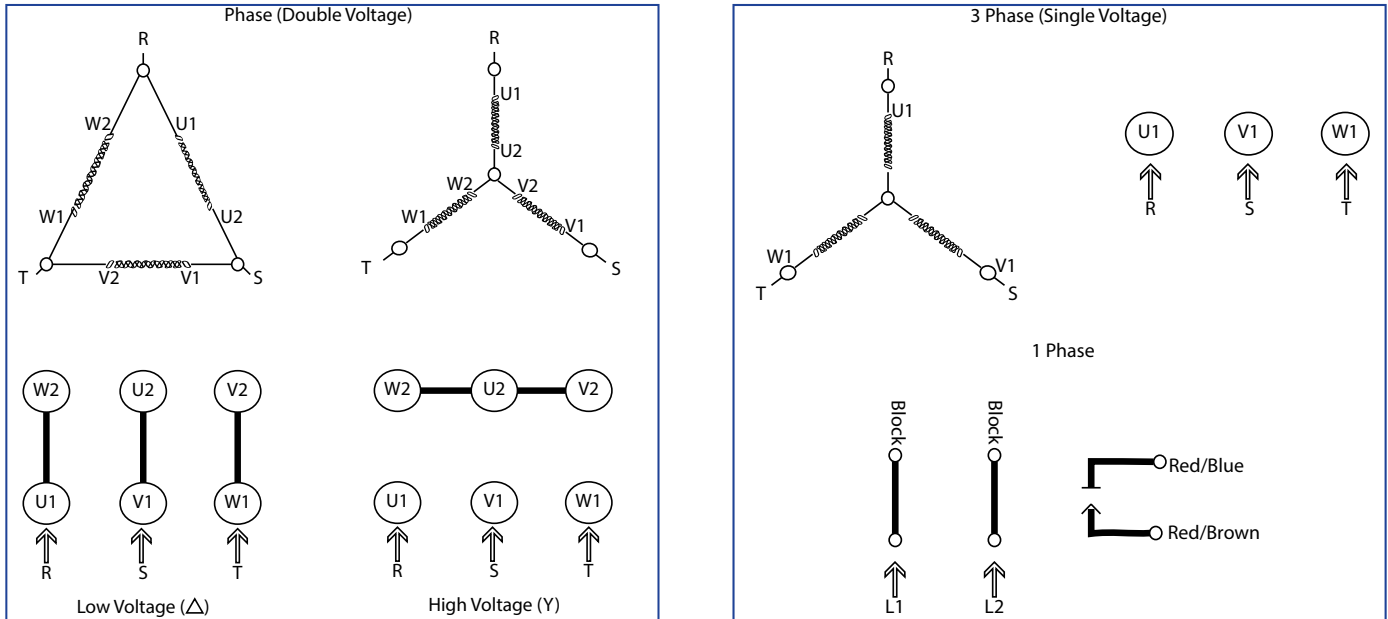

## Installation

- The vacuum pump should be placed in a well ventilated area on a flat surface. The pump causes low vibration, but a special base is not required. If desired, the pump can be bolted down.
- Place the vacuum pump in such a way that the oil monitor is easy to read.
- Upon installation, please check for and remove any obstruction around blower suction inlet and install under cover to avoid motor damage or electric shock caused by contact with water.
- To avoid overheating, ensure airflow to the pump in undisturbed.
- A distance of at least four (4) feet must be maintained between pump motor fan and wall to avoid overheating. Heat-resistant piping material is recommended within four (4) feet of the pump.
- Before running the pump, make sure vane rotation is clockwise. Refer to the arrow sticker on the motor for the direction of rotation. If the rotation is incorrect with three-phase motor, exchange any two lines of the three wires.
- Do not use the vacuum pump in areas where it would be exposed to high temperatures, excessive dust, smoke, rain, caustic air, or combustible air.

## Piping

- The diameter of the main pipe cannot be less than the diameter of the vacuum pump air inlet flange.
- When the diameter of the main pipe must be reduced, a tapered pipe should be used.
- The mounted pipes should cause no tension on the pump's flange. Be careful of overhung load from piping on pump's manifold. If necessary, install a pipe support to reduce stress on pump's manifold.
- Avoid unusual or sudden diameter shrinkage, enlargement of curvature of piping to ensure best pump air efficiency.
- Do not install a throttling device. The exhaust pipe should be installed in such a way as to prevent foreign matter from entering the pump.



## Maintenance

- Conveying air with high moisture may shorten the pump's service life. Air with a high moisture content should be avoided. If unavoidable, inspect pump's parts periodically to prevent pump damage or injury caused by corrosion.
- Bearings, vanes, and filters are consumable parts with limited life. Please inspect and replace periodically, especially in operations beyond normal ambient operating conditions.
- The inlet filter and the exhaust filter must be cleaned at regular intervals, depending on the amount of dust in the air being pumped. Blow out the filter cartridges with compressed air gun from the inside outwards.
- If the filter cartridge is too dirty to be cleaned, it must be replaced. The cartridges can be taken out after the removal of the filter cover.
- Cooling fan, hood, and motor should be inspected regularly for dirt. Dirt prevents cool air intake and may lead to overheating of the vacuum pump.
- Bearings are pre-lubricated and require no maintenance.

## Daily Maintenance

- Check oil color. If the oil is black or shows sediment, change the oil before use.
- Clear the inlet air filter by using compressed air to blow from the inside to the outside.
- Check the pipeline.
- Check oil sightglass, disassemble and wash if needed.
- Check oil level, add more if needed.
- Clear dust from outside of the cooler and the inner pipeline.

## Changing the Oil

To maintain optimal performance of your pump, oil should be replaced on a regular schedule.

1. Run the vacuum pump to heat up the oil, which will help the oil drain faster.
2. Cut off power to the pump.
3. Slowly open the oil plug (4).
4. Check that no sealing rings are damaged or leaking.
5. Close the oil plug (4) tightly.
6. Open oil plug (3), add oil up to the "Max" line and then tighten the plug.

## Replacing Exhaust Air Filter

We recommend changing the exhaust filter every other time you change the oil for optimal performance.

1. Stop the vacuum pump and check that there is no pressure in the system.
2. Remove the screw on the exhaust air lid.
3. Disassemble the top pieces.
4. Remove old filter.
5. Install new filter with new O ring into oil separator, matching the direction of the arrow on the filter.
6. Reattach top pieces and lid.

## Replacing Air Inlet Filter

1. Stop the vacuum pump and check that there is no pressure in the system.
2. Remove the three clips on the inlet air filter and open the inlet filter lid
3. Remove the old filter and replace with the new filter.
4. Close the air filter lid and reattach the three clips on the inlet air filter lid.

## Model Specifications

Model	Maximum Flow Rate	Ultimate Vacuum	Oil Max Temp	Noise Level	Oil Usage
	(CFM)	(inHg)	(°F)	dB(A)	(qt)
RX-10	6	29.96	177	61	0.5
RX-21	12	29.96	179	62	0.5
RX-25	15	29.96	179	62	0.5

Model	Inlet	Motor Rated Power		Motor Speed	Total Weight	Vacuum Pump Size
	(inches)	(kw)	(HP)	(rpm)	(lbs)	(inches)
RX-10	0.75	0.37	.5	1800	37.5	18x9x8
RX-21	0.75	0.75	1	1800	40	19x9x8
RX-25	0.75	1.1	1.5	1800	42	19x9x8

## Replacement Vanes, Filters, & Oil

Model	Vanes		Filters		Oil	
	Part No.	Qty.	Part No.	Qty.	Ambient Temperature 28-100°F	Ambient Temperature 50-201°F
RX-10	4310000	3	4000018	1	SHV46QT	SHV100QT
			4000028	1		
RX-21	4310000	3	4000018	1	SHV46QT	SHV100QT
			4000028	1		
RX-25	4310001	3	4000028	1	SHV46QT	SHV100QT
			W 712/4	1		

RX-10      RX-21      RX-25

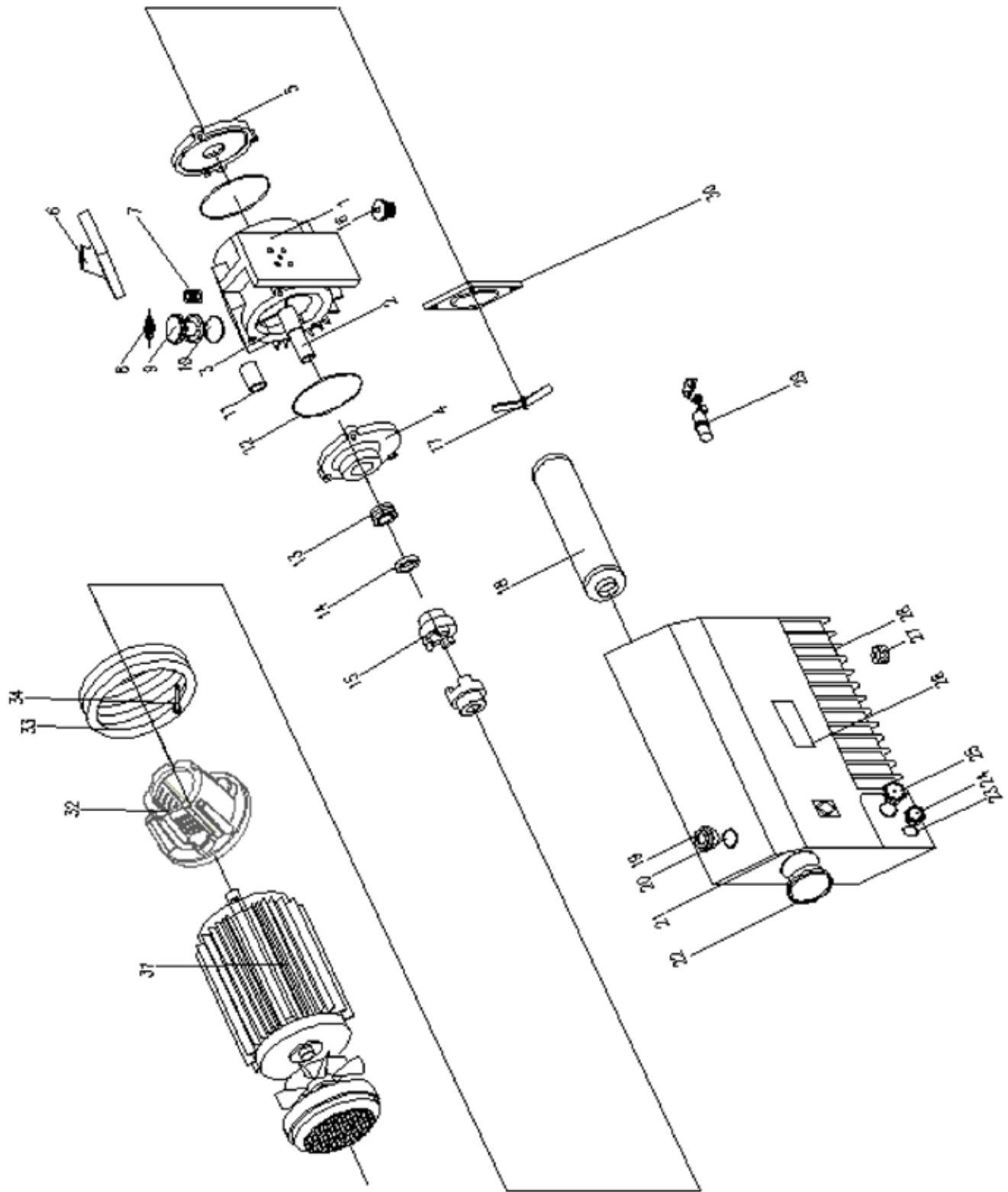

<b>RX-10</b>		
<b>Position No.</b>	<b>Description</b>	<b>Part No.</b>
1	Pump body	4000001
2	Rotor	4000002
4	End Plate A	4000004
5	End Plate B	4000005
6	Suction Valve Body	4000006
7	Suction Valve Spring	4000007
8	Air Inlet Screen	4000008
9	Suction Valve	4000009
10	Suction Valve O Ring	4000010
11	Bearing Race	4000011
12	End Plate O Ring	4000012
13	Bearing	4000013
14	Oil Seal	4000014
15	Coupling	4000015
16	Exhaust Valve	4000016
17	Separator Tensioner	4000017
18	Exhaust Filter	4000018
19	Oil Refuel Plug	4000019
20	Oil Refuel Plug O Ring	4000020
21	Base Cover O Ring	4000021
22	Base Cover	4000022
23	Drain Plug O Ring	4000023
24	Drain Plug	4000024
25	Oil Sight Glass	4000025
26	Tag	4000026
27	Vibration Isolator	4000027
29	Gas Ballast	4000029
30	Exhaust Lid	4000030
32	Connect Ring	4000031
33	Oil Cooler	4000032
34	Pipe Fitting	4000033

<b>RX-21</b>		
<b>Position No.</b>	<b>Description</b>	<b>Part No.</b>
1	Pump body	4000001
2	Rotor	4000002
3	Vane RX-21	4310000
4	End Plate A	4000004
5	End Plate B	4000005
6	Suction Valve Body	4000006
7	Suction Valve Spring	4000007
8	Air Inlet Screen	4000008
9	Suction Valve	4000009
10	Suction Valve O Ring	4000010
11	Bearing Race	4000011
12	End Plate O Ring	4000012
13	Bearing	4000013
14	Oil Seal	4000014
15	Coupling	4000015
16	Exhaust Valve	4000016
17	Separator Tensioner	4000017
18	Exhaust Filter	4000018
19	Oil Refuel Plug	4000019
20	Oil Refuel Plug O Ring	4000020
21	Base Cover O Ring	4000021
22	Base Cover	4000022
23	Drain Plug O Ring	4000023
24	Drain Plug	4000024
25	Oil Sight Glass	4000025
26	Tag	4000026
27	Vibration Isolator	4000027
28	Exhaust Filter	4000028
29	Gas Ballast	4000029
30	Exhaust Lid	4000030
32	Connect Ring	4000031
33	Oil Cooler	4000032
34	Pipe Fitting	4000033

<b>RX-25</b>		
<b>Position No.</b>	<b>Description</b>	<b>Part No.</b>
1	Pump body	4000001
2	Rotor	4000036
3	Vane RX-25	4310001
4	End Plate A	4000004
5	End Plate B	4000005
6	Suction Valve Body	4000006
7	Suction Valve Spring	4000007
8	Air Inlet Screen	4000008
9	Suction Valve	4000009
10	Suction Valve O Ring	4000010
11	Bearing Race	4000011
12	End Plate O Ring	4000012
13	Bearing	4000013
14	Oil Seal	4000014
15	Coupling	4000015
16	Exhaust Valve	4000016
17	Separator tensioner	4000017
18	Exhaust Filter - RX-25	4000028
19	Oil refuel Plug	4000019
20	Oil refuel Plug O Ring	4000020
21	Base Cover O Ring	4000021
22	Base Cover	4000022
23	Drain Plug O Ring	4000023
24	Drain Plug	4000024
25	Oil Sight glass	4000025
26	Tag	4000026
27	Vibration Isolator	4000027
28	Exhaust Filter-RX-25	4000028
29	Gas Ballast	4000029
30	Exhaust Lid	4000030
32	Connect Ring	4000031
33	Oil Cooler	4000032
34	Pipe Fitting	4000033

## Common Problems and Solutions

Problem	Possible Causes	Possible Solutions
Ultimate pressure failure; current overload; long time for vacuum	Blockage or leakage of inlet pipe or vacuum system	Check pipe for blockage and remove blockages.
	Vacuum pump pollution	Replace vacuum pump oil
	Exhaust filter blocked	Replace exhaust filter
	Air inlet filter blocked	Clean or replace air inlet filter
	Blocked suction valve	Clean suction valve and air inlet filter
	Limited air inlet/outlet pipe diameter	Replace pipes
	Leaking or broken oil pipe	Tighten or replace oil pipe fitting
	Leaking air tight ring or oil seal	Replace air tight ring or oil seal
	Broken or blocked exhaust valve	Replace or clean exhaust valve
	Stuck or broken vane	Clean rotor and vanes or replace vanes
	Incorrect space between rotor and pump	Adjust space between rotor and pump
	Broken components	Repair vacuum pump
Abnormal noise and overload	Loss phase of motor	Inspect power supply and cord
	Vanes rotating in the wrong direction	Adjust to correct rotation
	Long running time	Shut air inlet and run vacuum pump to raise temperature
	Excessively high oil temperature	Adjust vacuum pump oil to raise viscosity
	Excessively low oil temperature	Adjust vacuum pump oil to lower viscosity
	Dirty oil	Replace oil
	Infrequent oil changes (oil dark in color) or blocked exhaust filter	Clean vacuum pump and replace oil and exhaust filter
	Foreign body inside pump	Repair vacuum pump
	Broken vane or bearing	Repair vacuum pump
	Broken oil pipe connector	Replace oil pipe connector
Oil dark in color or low viscosity	Infrequent oil changes, incorrect oil mixture	Clean vacuum pump, change exhaust filter and lubrication
Thin oil	Using incorrect oil or incorrectly mixing oil	Clean vacuum pump, change exhaust filter and lubrication

## Common Malfunctions and Solutions continued

Malfunction	Possible Causes	Solution
Motor failure	Low voltage or excessively long power cord	Adopt suitable power cord and power supply
	Poor protection for motor overload	Choose correct motor overload protector according to electric current rating
	Broken fuse	Join fuse
	Exceeding capacitance in single phase motor	Repair motor
	Blocked vacuum pump or motor	Inspect and repair vacuum pump or motor
	Broken motor	Repair or replace motor
Pump operation failure, but motor still operational	Broken oil pipe connector	Replace oil pipe connector
Exhaust nozzle smoking	Floater valve blocked	Clean or replace floater valve
	Exhaust filter blocked	Reset or replace exhaust filter
Broken vane	Foreign body inside pump	Repair vacuum pump
	Corrosive gas inhalation	Repair vacuum pump and inspect flow
	Too much oil or liquid intake	Repair vacuum pump and inspect flow
	Incorrect rotation	Repair vacuum pump and correct rotation
Abnormal oil consumption	Broken air tight ring or oil seal	Replace air tight ring or oil seal
	Exhaust filter blocked	Reset or replace exhaust filter
	Blocked floater valve or oil leaking from exhaust nozzle	Clean or replace floater valve
	Oil Leak	Inspect and seal leak
Excessively high temperature of vacuum pump	Excessively high ambient air temperature at inlet	Strengthen cooling aeration; clean vanes, cooler and vane cover
	Partially blocked exhaust filter	Replace filter
	Bad aeration	Strengthen cooling aeration; clean vanes, cooler, and vane cover
	Insufficient lubrication	Replenish lubrication
	Unqualified lubrication	Clean vacuum pump, change exhaust filter and lubrication
	Limited air inlet/outlet pipe diameter	Replace pipes
	Incorrect voltage	Correct power supply voltage
	Blocked air inlet/outlet pipe or filters	Clean air inlet/outlet pipe and change filters





**R E P U B L I C**  
*Vacuum Pumps*<sup>®</sup>

**Republic Vacuum Pumps<sup>®</sup>**

5131 Cash Road

Dallas, TX 75247

(800) 847-0380

[www.republicsales.com](http://www.republicsales.com)

[info@republicsales.com](mailto:info@republicsales.com)