

Republic offers the VRT series of dry-running rotary vane vacuum pumps and are ideally suited for oil-free applications. They are single stage, air-cooled and direct driven for continuous operation. The design is one of the most reliable and simplest vacuum pumps available. These rugged pumps are simple to install and easy to service and maintain. The smaller pumps come with a motor integrated, while the larger pumps are available with or without motor. These pumps have a displacement ranging from 4.7 to 176 CFM (8 to 300 m<sup>3</sup>/hr) and a maximum vacuum of 150 torr.

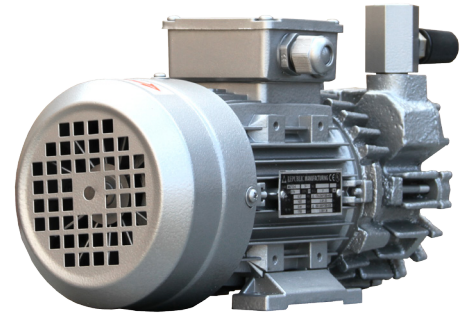

The VRT series is used in a variety of industries such as vacuum lifting, woodworking, environmental applications electronics, packaging, conveying, robotics, medical vacuum/central vacuum, and printing.

### PERFORMANCE

Model	Displacement (CFM/m <sup>3</sup> /hr)		Ultimate Vacuum Max (In. Hg./Torr/mbar)	Noise Level (dB)		Weight (lb/kg)
	50 Hz	60 Hz		50 Hz	60 Hz	
408	4.7/8.0	5.4/9.2	25.1/112.5/150	58	61	29/13

Model	Phase	Motor Output		Voltage (V)		Speed (rpm)	
		50 Hz	60 Hz	50 Hz	60 Hz	50 Hz	60 Hz
408	3~	0.37 kw	0.59 hp	175-260/300-450	202-300/350-520	1420	1700
	1~	0.37 kw	0.59 hp	230	230	1380	1630

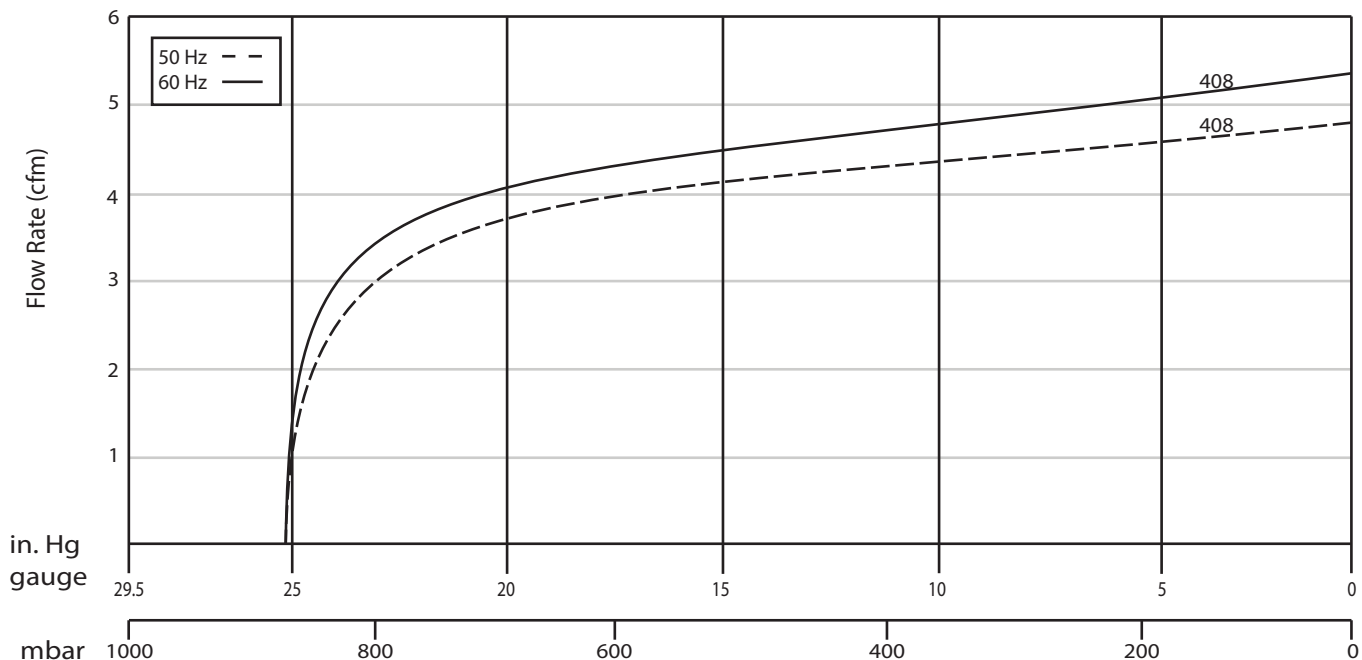

All measurements are ±10%

## APPROXIMATE DIMENSIONS

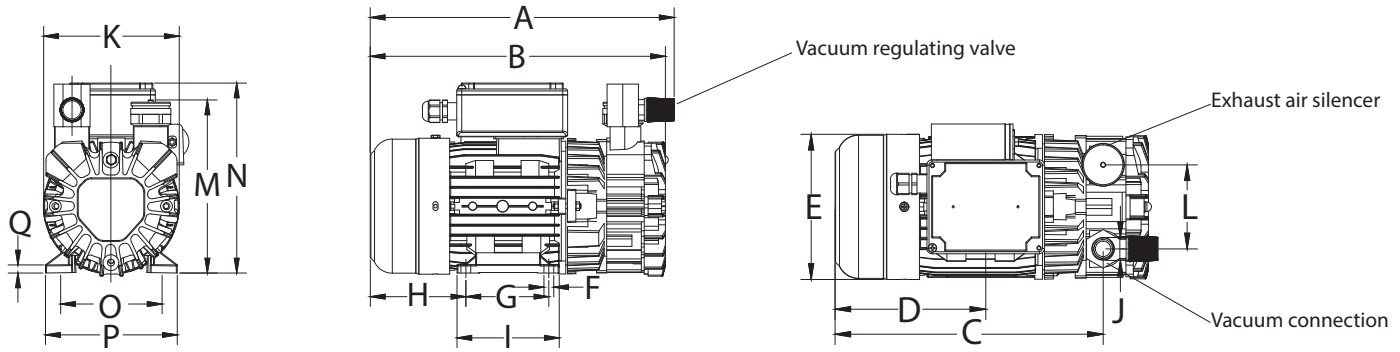

Model	Unit	A	B	C	D	E	F	G	H	I	J	K	L	M	N	O	P	Q
408	in	12.36	11.89	10.35	6.34	5.51	0.30	3.56	3.72	4.11	1.00	5.22	3.23	6.61	6.95	4.41	5.18	0.39
	mm	314	302	263	161	140	7.5	90.5	94.5	104.5	24.5	132.5	82	168	176.5	112	131.5	10

### Optional Accessories

- Inlet filter
- Inlet check valve
- Vacuum gauge
- Motor starter
- Control panel
- PLC