

Republic offers a complete line of centrifugal blowers for vacuum or compressed air applications. Centrifugal blowers provide dry, clean, oil-free air and require low energy consumption. Unlike compressed air systems, this series is safe to run at low pressure, and allows for increased production speeds or levels.

The RB1200HC is the most versatile of the centrifugal blower series. The blower comes with ceramic hybrid bearings, rotatable outlet discharge, easy to remove stainless steel bearing housing assembly, and zinc plated steel motor pulley.



PERFORMANCE

Vacuum

Pressure

60Hz

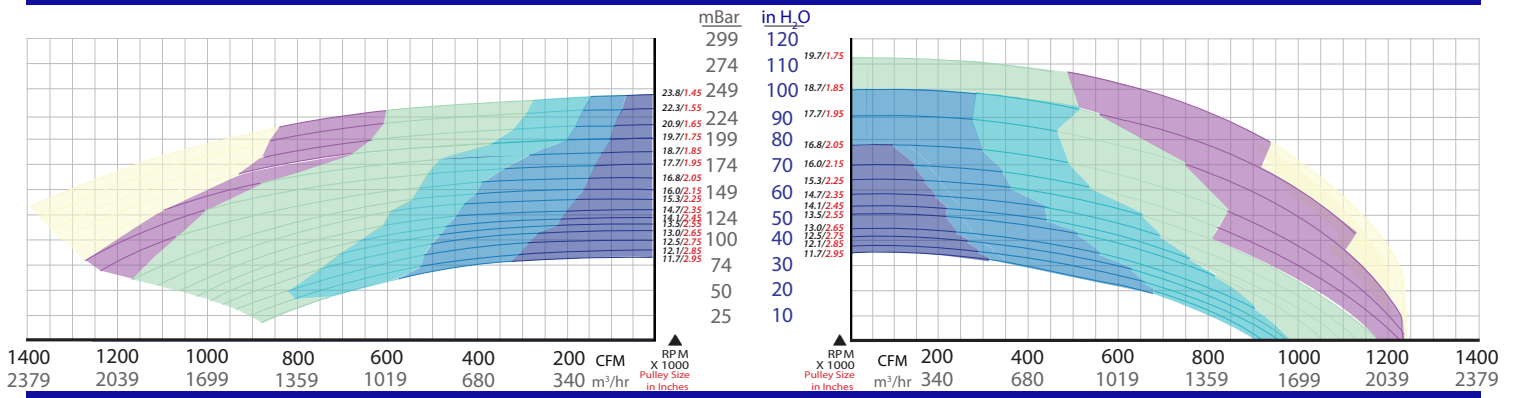

50Hz

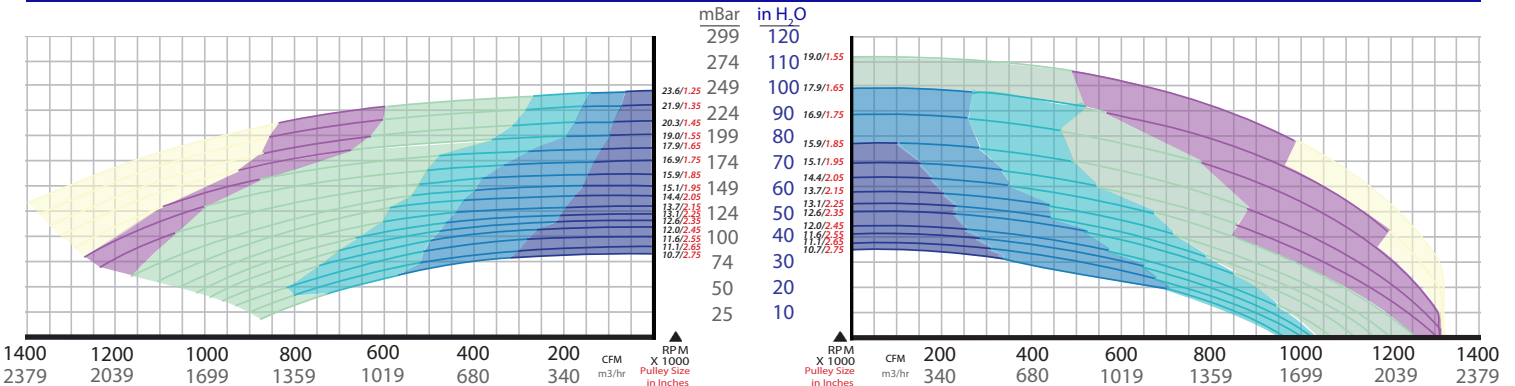

Model	Frequency (Hz)	HP	Max Flow (CFM/m ³ /hr)	Max Vacuum (in. H ₂ O/mbar)	Max Pressure (in. H ₂ O/mbar)	Sound Level (db)		Weight (lb/kg)	Retro Kit Weight (lb/kg)
						with Enclosure	without Enclosure		
RB1200HC	50	5 (184TC)	325/552	98/244	78/194	82/96		160/73	79/36
	60		325/552	98/244	78/194				
	50	7.5 (213TC)	675/1,147	98/244	100/250	82/96		167/76	
	60		675/1,147	98/244	100/250				
	50	10 (215TC)	1020/1733	97/242	99/247	82/96		205/93	
	60		975/1,657	97/242	99/247				
	50	15 (254TC)	1,225/2,081	95/237	112/280	82/96		245/111	
	60		1,200/2,039	95/237	112/280				
	50	20 (256TC)	1,300/2,209	92/230	108/270	82/96		348/158	
	60		1,270/2,158	92/230	108/270				
	50	25 (284TSC)	1,380/2,345	85/212	80/200	82/96		440/200	
	60		1,380/2,345	85/212	80/200				

APPROXIMATE DIMENSIONS

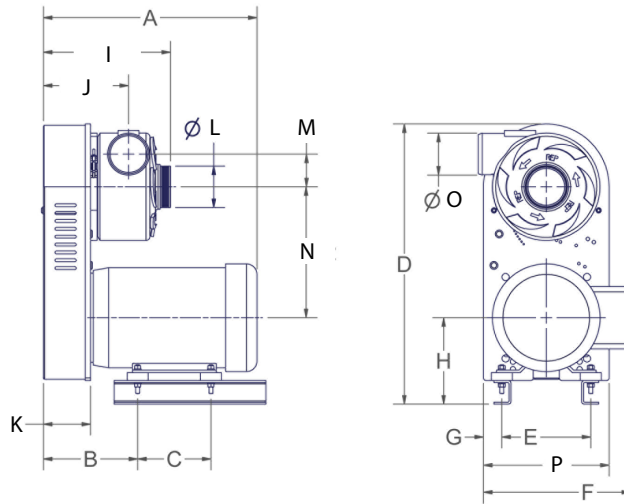

HP	Unit	A	B	C	D	E	F	G	H	I	J	K	L	M	N	O	P
5 (184TC)	in	17.00	8.00	5.50	26.00	8.00	13.00	2.25	7.50	12.00	8.00	4.50	3.96	3.00	12.50	4.00	12.00
	mm	433	206	140	660	194	327	57	191	308	206	114	101	79	318	102	305
7.5 (213TC)	in	20.00	9.00	5.50	27.00	8.50	14.00	1.75	8.25	12.00	8.00	4.50	3.96	3.00	12.50	4.00	12.00
	mm	508	229	140	679	216	357	45	210	308	206	114	101	79	318	102	305
10 (215TC)	in	20.00	9.00	7.00	27.00	8.50	14.00	1.75	8.25	12.00	8.00	4.50	3.96	3.00	12.50	4.00	12.00
	mm	508	229	178	679	216	357	45	210	308	206	114	101	79	318	102	305
15 (254TC)	in	24.50	9.50	8.25	27.75	8.50	16.00	1.00	9.25	12.00	8.00	4.50	3.96	3.00	12.50	4.00	12.00
	mm	622	241	210	705	216	408	25	235	308	206	114	101	79	318	102	305
20 (256TC)	in	24.50	9.50	10.00	27.75	10.00	16.00	1.00	9.25	12.00	8.00	4.50	3.96	3.00	12.50	4.00	12.00
	mm	622	241	254	705	254	408	25	235	308	206	114	101	79	318	102	305
25 (284TC)	in	26.00	9.50	9.50	27.00	11.00	18.00	0.50	8.50	12.00	8.00	4.50	3.96	3.00	12.50	4.00	12.00
	mm	662	241	241	686	279	459	13	216	308	206	114	101	79	318	102	305

Available Options

Republic Centrifugal Blowers are made to order, and can be customized to fit almost any application. Many common options and accessories are listed below. For additional options, please contact Republic or your local distributor.

Advantages

- 5-25 Horsepower – up to 23,800 rpm
- 16 Groove belt for long life
- Most versatile blower
- Ceramic hybrid bearings
- Multi-lip seals on both ends of the shaft
- Easy to remove bearing/impeller housing for quick repair
- Blower outlet discharge is rotatable
- Precision balanced shaft/impeller assemblies
- Stainless steel blower pulley, zinc plated steel motor pulley, aluminum blower housing
- 6061 T6 aluminum impeller
- Bearing housing is steel construction for extra rigidity
- Operational with all types of motors– washdown, explosion proof, high efficiency and hydraulic
- 100% Operational performance and vibration tested
- One year warranty

Options

- Hard anodized bearing housing assembly
- Inlet and outlet flanges
- Water-cooled blower

Accessories

- Enclosures for noise control
- Exhaust silencer
- Starter panel
- Variable frequency drive

