



FEATURES

- Single stage, direct-driven
- Continuous, contactless, oil-free operation
- Energy efficient for substantial savings
- Minimal downtime
- Air-cooled
- Made in the U.S.A.
- Simple installation
- Virtually maintenance-free
- Low noise levels
- Upgraded bearings
- Top-performing Viton™ seals

APPLICATIONS

Any oil-free application including:

- Forming
- Dehydration
- Packaging
- Conveying
- Printing
- Environmental
- Medical
- CNC vacuum hold down

OPTIONAL ACCESSORIES

- Inlet filter
- Vacuum gauge
- Motor starter
- Control panel
- Central systems supporting 1-6 pumps

60Hz

©Republic Manufacturing

IE3

RCV-250/300

PERFORMANCE (60HZ)

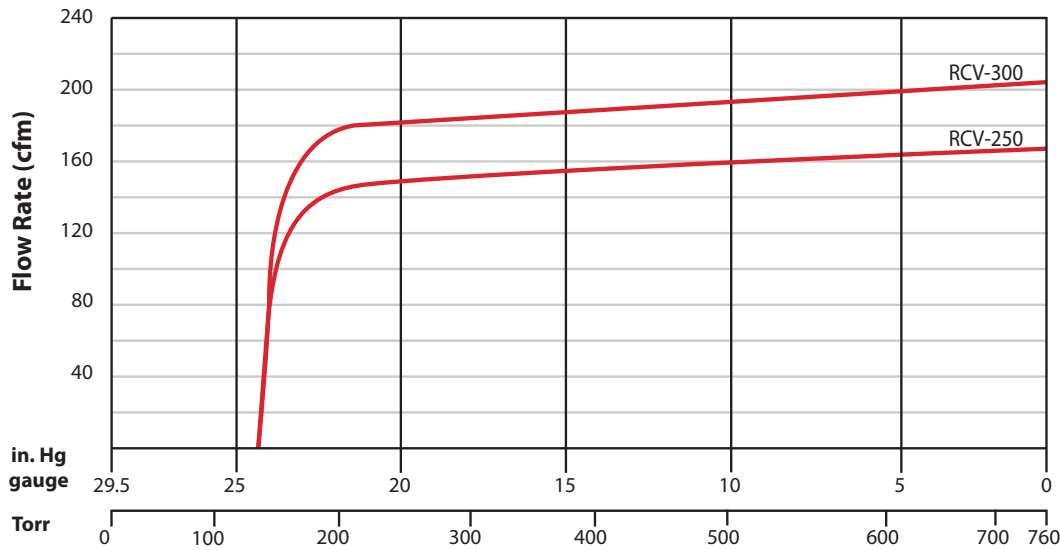

Model	Hz	Displacement (cfm)	Ultimate Continuous Vacuum (in. Hg/Torr)	Motor Output	Motor Speed (RPM)	Voltage (V)	Motor Amperage (A)	Noise Level (dBA)	Approx. Weight (lb)
250	60	166	24.0/150	7.5 hp	3450	208-230/460	18.6-17.6/8.8	82	450
300	60	203	24.0/150	10 hp	3450	208-230/460	18.6-17.6/8.8	82	618

All measurements are ±10%

APPROXIMATE DIMENSIONS

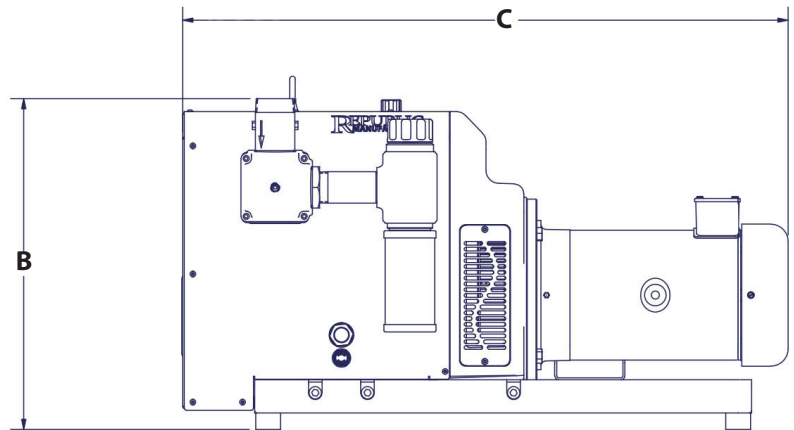
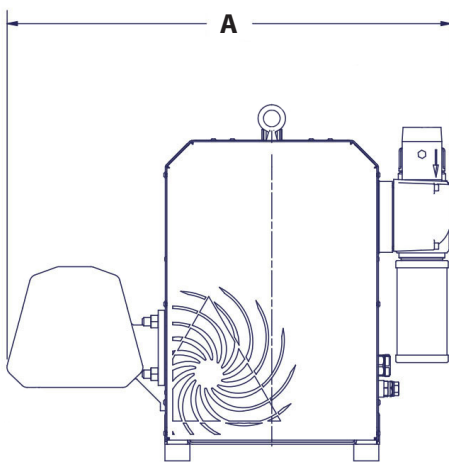

Model	A	B	C	Inlet	Discharge
250	26.63"	20.00"	36.31"	2" MNPT	2.5" FNPT
300	26.63"	20.00"	38.63"	2" MNPT	2.5" FNPT

CONTACT

